



BCM 4.0 Installation Checklist and Quick Start Guide

BCM 4.0 Business Communications Manager

Document Status: **Standard**

Document Version: **02**

Part Code: **N0060602**

Date: **June 2006**

Copyright © 2006 Nortel Networks, All Rights Reserved

All rights reserved.

The information in this document is subject to change without notice. The statements, configurations, technical data, and recommendations in this document are believed to be accurate and reliable, but are presented without express or implied warranty. Users must take full responsibility for their applications of any products specified in this document. The information in this document is proprietary to Nortel Networks.

Trademarks

Nortel, the Nortel logo, and the Globemark are trademarks of Nortel Networks.

Microsoft, MS, MS-DOS, Windows, and Windows NT are trademarks of Microsoft Corporation.

All other trademarks and registered trademarks are the property of their respective owners.

SOFTWARE LICENSE

NORTEL NETWORKS INC. ("NORTEL NETWORKS") TELECOMMUNICATION PRODUCTS

THIS LEGAL DOCUMENT IS A LICENSE AGREEMENT ("License") BETWEEN YOU, THE END-USER ("CUSTOMER") AND NORTEL NETWORKS. PLEASE READ THIS LICENSE CAREFULLY BEFORE USING THE SOFTWARE. BY USING THIS SOFTWARE, YOU, THE CUSTOMER, ARE AGREEING TO BE BOUND BY THE TERMS OF THIS LICENSE. IF YOU DO NOT AGREE TO THE TERMS OF THIS LICENSE, RETURN THE UNUSED SOFTWARE AND THE ASSOCIATED DOCUMENTATION TO NORTEL NETWORKS THROUGH A NORTEL NETWORKS AUTHORIZED DISTRIBUTOR WITHIN FIVE (5) DAYS OF YOUR ACQUISITION OF THE SOFTWARE FOR A REFUND.

Subject to the terms hereinafter set forth, NORTEL NETWORKS grants to CUSTOMER and/or its representatives, with a "need to know," a personal, non-exclusive license (1) to use the licensed software, proprietary to NORTEL NETWORKS or its suppliers and (2) to use the associated documentation. CUSTOMER is granted no title or ownership rights, in or to the licensed software, in whole or in part, and CUSTOMER acknowledges that title to and all copyrights, patents, trade secrets and/or any other intellectual property rights to and in all such licensed software and associated documentation are and shall remain the property of NORTEL NETWORKS and/or NORTEL NETWORKS' suppliers. The right to use licensed software may be restricted by a measure of usage of applications based upon number of lines, number of ports, number of terminal numbers assigned, number of users, or some similar measure. Expansion beyond the specified usage level may require payment of an incremental charge or another license fee.

NORTEL NETWORKS considers the licensed software to contain "trade secrets" of NORTEL NETWORKS and/or its suppliers. Such "trade secrets" include, without limitation thereto, the specific design, structure and logic of individual licensed software programs, their interactions with other portions of licensed software, both internal and external, and the programming techniques employed therein. In order to maintain the "trade secret" status of the information contained within the licensed software, the licensed software is being delivered to CUSTOMER in object code form only.

NORTEL NETWORKS or any of its suppliers holding any intellectual property rights in any licensed software, and/or any third party owning any intellectual property rights in software from which the licensed software was derived, are intended third party beneficiaries of the License. All grants of rights to use intellectual property intended to be accomplished by this License are explicitly stated. No other grants of such rights shall be inferred or shall arise by implication.

CUSTOMER warrants to NORTEL NETWORKS that CUSTOMER is not purchasing the rights granted by this License in anticipation of reselling those rights.

CUSTOMER shall:

- Hold the licensed software in confidence for the benefit of NORTEL NETWORKS and/or NORTEL NETWORKS' suppliers using no less a degree of care than it uses to protect its own most confidential and valuable information; and
- Keep a current record of the location of each copy of licensed software made by it; and
- Install and use each copy of licensed software only on a single CPU at a time (for this purpose, single CPU shall include systems with redundant processing units); and

- Affix to each copy of licensed software made by it, in the same form and location, a reproduction of the copyright notices, trademarks, and all other proprietary legends and/or logos of NORTEL NETWORKS and/or NORTEL NETWORKS' suppliers, appearing on the original copy of such licensed software delivered to CUSTOMER; and retain the same without alteration on all original copies; and
- Issue instructions to each of its authorized employees, agents and/or representatives to whom licensed software is disclosed, advising them of the confidential nature of such licensed software and to provide them with a summary of the requirements of this License; and
- Return the licensed software and all copies through an Authorized Distributor to NORTEL NETWORKS at such time as the CUSTOMER chooses to permanently cease using it.

CUSTOMER shall not:

- Use licensed software (i) for any purpose other than CUSTOMER's own internal business purposes and (ii) other than as provided by this License; or
- Allow anyone other than CUSTOMER's employees, agents and/or representatives with a "need to know" to have physical access to licensed software; or
- Make any copies of licensed software except such limited number of object code copies in machine readable form only, as may be reasonably necessary for execution or archival purposes only; or
- Make any modifications, enhancements, adaptations, or translations to or of licensed software, except as may result from those CUSTOMER interactions with the licensed software associated with normal use and explained in the associated documentation; or
- Attempt to reverse engineer, disassemble, reverse translate, decompile, or in any other manner decode licensed software, in order to derive the source code form or for any other reason; or
- Make full or partial copies of any documentation or other similar printed or machine-readable matter provided with licensed software unless the same has been supplied in a form by NORTEL NETWORKS intended for periodic reproduction of partial copies; or
- Export or re-export licensed software and/or associated documentation by downloading or otherwise from the fifty states of the United States and the District of Columbia.

PLEASE REFER TO THE NEXT PAGE

Except for Java Product (as defined herein below), CUSTOMER may assign collectively its rights under this License to any subsequent owner of the associated hardware, but not otherwise, subject to the payment of the then current license fee for new users, if any. No such assignment shall be valid until CUSOMTER (1) has delegated all of its obligations under this License to the assignee; and (2) has obtained from the assignee an unconditional written assumption of all such obligations; and (3) has provided NORTEL NETWORKS a copy of such assignment, delegation and assumption; and (4) has transferred physical possession of all licensed software and all associated documentation to the assignee and destroyed all archival copies. Except as provided, neither this License nor any rights acquired by CUSTOMER through this License are assignable. Any attempted assignment of rights and/or transfer of licensed software not specifically allowed shall be void and conclusively presumed a material breach of this License.

If NORTEL NETWORKS (i) claims a material breach of this License, and (ii) provides written notice of such claimed material breach to CUSTOMER and (iii) observes that such claimed material breach remains uncorrected and/or unmitigated more than thirty (30) days following CUSTOMER's receipt of written notice specifying in reasonable detail the nature of the claimed material breach, then CUSTOMER acknowledges that this License may be immediately terminated by NORTEL NETWORKS and CUSTOMER further acknowledges that any such termination shall be without prejudice to any other rights and remedies that NORTEL NETWORKS may have at law or in equity.

EXPRESS LIMITED WARRANTIES FOR ANY ITEM OF LICENSED SOFTWARE, IF ANY, WILL BE SOLELY THOSE GRANTED DIRECTLY TO CUSTOMER BY DISTRIBUTOR. OTHER THAN AS SET FORTH THEREIN, THIS LICENSE DOES NOT CONFER ANY WARRANTY TO CUSTOMER FROM OR BY NORTEL NETWORKS.

THE LICENSED SOFTWARE IS PROVIDED BY NORTEL NETWORKS "AS IS" AND WITHOUT WARRANTY OF ANY KIND OR NATURE, WRITTEN OR ORAL, EXPRESS OR IMPLIED, INCLUDING (WITHOUT LIMITATION) THE IMPLIED WARRANTIES OF MERCHANTABILITY AND OF FITNESS FOR A PARTICULAR PURPOSE.

THIS LIMITATION OF WARRNATIES WAS A MATERIAL FACTOR IN THE ESTABLISHMENT OF THE LICENSE FEE CHARGED FOR EACH SPECIFIC ITEM OF SOFTWARE LICENSED.

IN NO EVENT WILL NORTEL NETWORKS AND/OR NORTEL NETWORKS' SUPPLIERS AND THEIR DIRECTORS, OFFICERS, EMPLOYEES OR AGENTS BE LIABLE TO OR THROUGH CUSTOMER FOR INCIDENTAL, INDIRECT, SPECIAL, CONSEQUENTIAL, PUNITIVE, OR EXEMPLARY DAMAGES OF ANY KIND, INCLUDING LOST PROFITS, LOSS OF BUSINESS OR BUSINESS INFORMATION, BUSINESS INTERRUPTION, OR OTHER ECONOMIC DAMAGE, AND FURTHER INCLUDING INJURY TO PROPERTY, AS A RESULT OF USE OR INABILITY TO USE THE LICENSED SOFTWARE OR BREACH OF ANY WARRANTY OR OTHER TERM OF THIS LICENSE, REGARDLESS OF WHETHER NORTEL NETWORKS AND/OR NORTEL NETWORKS' SUPPLIERS WERE ADVISED, HAD OTHER REASON TO KNOW, OR IN FACT KNEW OF THE POSSIBILITY THEREOF.

Restricted Rights. Use, duplication or disclosure by the United States government is subject to the restrictions as set forth in the Right in Technical Data and Computer Software Clauses in DFARS 252.227-7013(c) (1) (ii) and FAR 52.227-19(c) (2) as applicable.

The rights and obligations arising under this License shall be construed in accordance with the laws of the State of Tennessee. If for any reason a court of competent jurisdiction finds any provision of this License or portion thereof to be unenforceable, that provision of the License shall be enforced to the maximum extent permissible so as to effect the intent of the parties and the remainder of this License shall continue in full force and effect.

This License constitutes the entire agreement between the parties with respect to the use of the licensed software and the associated documentation, and supersedes all prior or contemporaneous understandings or agreements, written or oral, regarding such subject matter. No amendment to or modification of this License will be binding unless in writing and signed by a duly authorized representative of NORTEL NETWORKS.

Contents

Chapter 1	
Getting started	7
About this guide	7
Purpose	7
Audience	7
Precautions	7
Installation and configuration summary	8
Default values	9
Tools, data, and parameters	10
Checklists	11
General checklist	11
Main unit components checklist	11
Expansion unit and media bay modules components checklist	12
Chapter 2	
System overview	13
Main units	13
BCM expansion unit (BCM400 only)	14
Element Manager	15
Startup Profile	15
Chapter 3	
Physical installation	17
Mounting a BCM main unit and expansion unit	17
Installing a BCM unit in a rack	17
Installing a BCM unit on a wall	19
Installing a BCM unit on a flat surface	20
Connecting the expansion unit to the main unit	21
Installing the MBMs	21
Connecting the MBM wiring	24
Wiring the FEM	29
Powering up the BCM system	29
Connecting the data networking hardware	30
Unpacking, placing, and wiring telephone hardware	31
Chapter 4	
Connection and configuration procedures	33
Connecting to the BCM system	33
Connecting through the Ethernet crossover cable	34

Connecting through the serial port	34
Downloading from the BCM web page	36
Generating a software keycode	37
Configuring the BCM system parameters	37
Startup Profile times and LED sequence	42
Configuring the MBMs	42
Customizing other parameters	43

Chapter 1

Getting started

IMPORTANT!

Print this chapter to record the progress of the BCM system installation and configuration. The tables and checklists are valuable tools to guide you through the installation process.

About this guide

The *BCM 4.0 Installation Checklist and Quick Start Guide* describes how to install and configure BCM200 and BCM400 systems running Business Communications Manager (BCM) 4.0 software.

Although not specifically covered in this document, BCM 4.0 software functions with the BCM1000 system. For more information, refer to the *BCM 3.7 for BCM1000 Installation and Maintenance Guide* and the *BCM 4.0 for BCM1000 Installation and Maintenance Guide Addendum*.

Purpose

The procedures described in this guide relate to the hardware of the BCM system. This guide provides task-based information on how to install the hardware components and perform basic configuration tasks. For more detailed configuration information, consult the appropriate technical documentation.

Audience

This guide is directed to experienced installers responsible for installing and configuring BCM 4.0 systems.

If this is your first BCM installation or if you require more detailed information, refer to the *BCM200/400 4.0 Installation and Maintenance Guide*.

Precautions

Nortel recommends that you read this document in its entirety before starting the described procedures.

Observe the general safety precautions against personal injury and equipment damage outlined in the Regional Installation Safety Manual (ISM) at all times.

Prior to starting the procedures presented in this document, arrange all materials, tools, and test equipment at the work location to minimize fatigue and inconvenience.



The clock icon indicates that a procedure or task has been timed; the time is provided next to the icon.



Installation and configuration summary

Table 1 provides the tasks to install and configure a BCM system.

Table 1 Installation and configuration checklist (Sheet 1 of 2)

<input checked="" type="checkbox"/>		Task	Reference	Comments
	N/A	Review the BCM system hardware and configuration tools	“System overview” on page 13	
	N/A	Verify that you have the tools, materials, and data required	“Tools, data, and parameters” on page 10	
	15 min.	Complete the checklists before installing the BCM system	“Checklists” on page 11	
	12 min.	Mount the BCM main unit: <ul style="list-style-type: none"> • Rack-mount • Wall-mount • Desk-mount 	“Mounting a BCM main unit and expansion unit” on page 17	
	12 min.	(Optional) Mount the BCM expansion unit: <ul style="list-style-type: none"> • Rack-mount • Wall-mount • Desk-mount 	“Mounting a BCM main unit and expansion unit” on page 17	
	1 min.	(Optional) Connect the BCM expansion unit to the BCM main unit	“Connecting the expansion unit to the main unit” on page 21	
	4 min.	Install MBMs in the BCM main unit and expansion unit	“Installing the MBMs” on page 21	
	15 min.	Connect MBM wiring	“Connecting the MBM wiring” on page 24	
	6 min.	Apply power to the BCM system	“Connecting the MBM wiring” on page 24	
	7 min.	(Optional) Connect the WAN card and modem to the BCM system	“Connecting the data networking hardware” on page 30	
	9 min./set	Install telephony hardware	“Unpacking, placing, and wiring telephone hardware” on page 31	
	9 min.	Connect to the BCM system (LAN or Ethernet crossover cable)	“Connecting to the BCM system” on page 33	
	15 min.	Download and install Element Manager	“Downloading from the BCM web page” on page 36	
	5 min.	Enter keycode	“Generating a software keycode” on page 37	

Table 1 Installation and configuration checklist (Sheet 2 of 2)

		Task	Reference	Comments
	15 min.	Configure the required BCM system parameters (Element Manager or Startup Profile)	“Configuring the BCM system parameters” on page 37	
	1 min./MBM	Configure the MBMs with Element Manager	“Configuring the MBMs” on page 42	
	N/A	(Optional) Complete the configuration by customizing other parameters	“Customizing other parameters” on page 43	

Note 1: The stated times can vary depending on the number and type of items installed.

Note 2: For more detailed information, refer to the *BCM200/400 4.0 Installation and Maintenance Guide*.

Default values

Use [Table 2](#) and [Table 3](#) to view and record changes to default BCM system information.

Table 2 Default IP addresses

Port	IP address (subnet mask)	New IP address
LAN 1	10.10.10.1 (255.255.255.0)	
LAN 2	10.10.11.1 (255.255.255.0)	

Table 3 Default user names and passwords

Tool	User ID User name	Password	New password
Element Manager	nnadmin	PlsChgMe!	
BCM 4.0 web page (http:// [IP address])	nnadmin	PlsChgMe!	
Telset Administration (F9*8 and F**Config)	SETNNA (738662)	CONFIG (266344)	
Telset Administration voice mail (Feature 983)	SETNNA (738662)	CONFIG (266344)	
Telset Administration initialize voice mail (Feature 983)	–	CONFIG (266344)	

Tools, data, and parameters

Use [Table 4](#) and [Table 5](#) to record information about tools and information.

Table 4 Tools

Description	Value	Comments
Laptop (or PC) with: <ul style="list-style-type: none"> Windows 98 SE, Windows 2000, Windows XP minimum 256 MB, recommended 512 MB 150 MB free disk space 		
Mounting hardware rack-mount brackets, wall-mount bracket, or rubber feet; an optional plywood backboard 3/4 in. (2 cm) thick for wall-mount installations.		
Phillips #2 screwdriver		
Common screwdriver		
Pliers		
Antistatic ground strap		
Connecting tool		
25-pair cable with RJ-21 connector		
Cat 5 Ethernet cable with RJ-45 connectors		
Surge protector		
Uninterruptible Power Supply (UPS)		
3.5 mm mono audio jack (for external music source)		

Table 5 System information (Sheet 1 of 2)

Description	Value	Comments
Profile		
Initial IP address and netmask for each network interface		
Primary (and optional secondary) DNS servers		
Default next-hop router (default gateway)		
DHCP server settings		
Telephony Startup template (DID/PBX)		
Fractional T1 channel numbers		
System name		
WAN link protocol		
Frame relay DLCI/CIR (if applicable)		

Table 5 System information (Sheet 2 of 2)

Description	Value	Comments
V.90 modem settings (North America only)		
SNMP agent (security, version)		
SNMP manager IP address		
SNMP community string		

Checklists

Before installing the BCM hardware, complete the following checklists (see the *BCM200/400 4.0 Installation and Maintenance Guide* for more information).

General checklist

- Determine the location for the main unit (and optional expansion unit), telephones, and other equipment based on spacing and electrical requirements.
- Order the required trunks from the central office.
- Ensure that you have all the equipment and supplies you need to install the system.
- Ensure that the system complies with the environmental requirements.
- Ensure that the system complies with the electrical requirements.
- Ensure that the system complies with the physical requirements.

Main unit components checklist

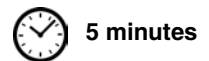

5 minutes

Check that you have the following components, and inspect the components for any damage:

- one main unit
- one power supply cable
- four rubber feet
- one set of rack-mount brackets
- documentation CD
- BCM 4.0 Installation Checklist and Quick Start Guide*

Expansion unit and media bay modules components checklist



5 minutes

Check that you have the following components, and inspect the components for any damage:

- one expansion unit
- one power supply cable
- one expansion cable (use only supplied Ethernet cable)
- four rubber feet
- the correct media bay modules (MBM)

Chapter 2

System overview

The BCM system includes the following primary hardware components and configuration tools:

- “Main units” on page 13
- “BCM expansion unit (BCM400 only)” on page 14
- “Element Manager” on page 15
- “Startup Profile” on page 15

A BCM 4.0 system requires BCM 4.0 software operating on BCM200 or BCM400 hardware.

Refer to the chapter “Introducing the BCM hardware” in the *BCM200/400 4.0 Installation and Maintenance Guide* for more detailed information.

Main units

The central hardware component in the BCM system is the main unit. The BCM system contains one main unit and an optional expansion unit (BCM400 only). The types of main units are:

- BCM200 (see [Figure 1](#))
- BCM400 (see [Figure 2](#))

Note: The BCM400 main unit is available in either standard or redundant feature option (RFO) configurations.

Figure 1 BCM200 main unit ports and connectors

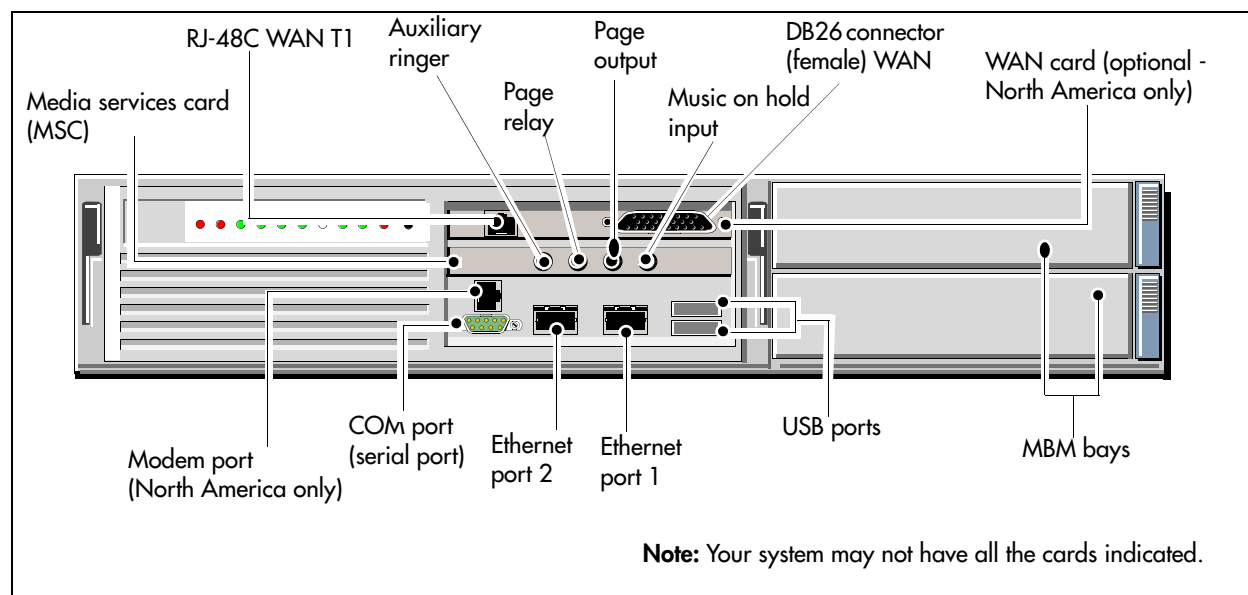
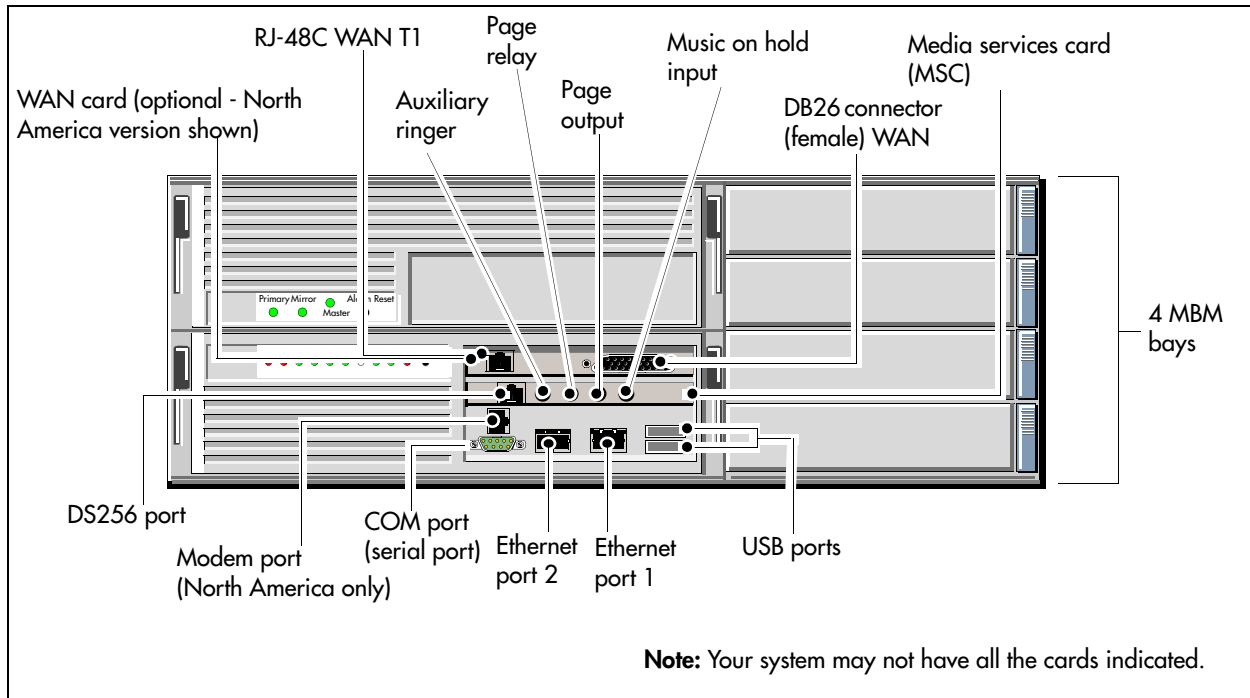

Figure 2 BCM400 main unit ports and connectors



BCM expansion unit (BCM400 only)

The BCM400 system can have one BCM expansion unit that contains six additional bays for media bay modules (MBMs). The BCM expansion unit is not compatible with the BCM200 system.

The supplied DS256 cable is 5 m (16 ft.) long and connects into a DS256 port on the main unit, and into a DS256 port on the center panel of the expansion unit (see [Figure 3](#)). Use of any other cable is not supported.



Note: The number of MBMs that can be installed is determined by the number of DS30 buses required by the MBMs and the number of buses available. It is not dependent on the number of physical MBM bays available.

Figure 3 BCM expansion unit DS256 port location

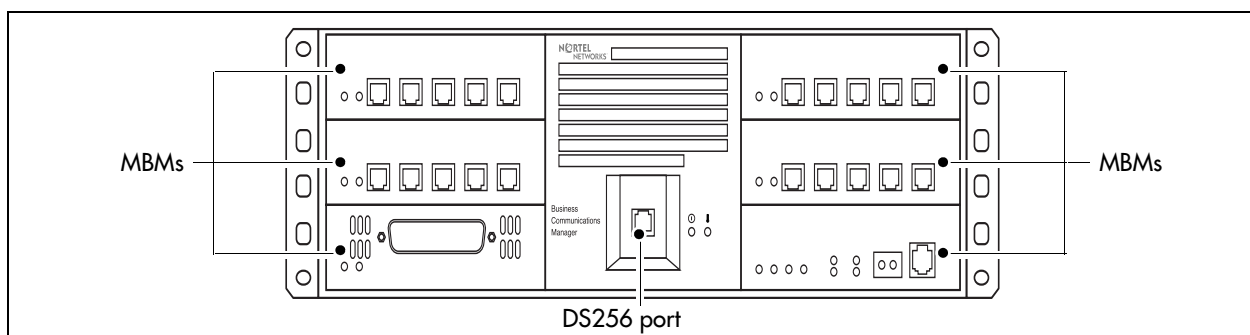

Element Manager

The primary management application for configuring and administering the BCM system is Element Manager.

Element Manager is a client-based management application that runs on a Windows computer. You can connect to BCM system devices over an IP network and configure, administer, and monitor BCM system devices.

Element Manager has the following system requirements:

- Windows: Windows 98 SE, Windows 2000, Windows XP
- RAM: minimum 256 MB, recommended 512 MB
- free space: 150 MB

The Element Manager application can be downloaded from the BCM web page (on the BCM main unit) or from the Nortel support web site.

Element Manager allows you to connect to the BCM system devices through the LAN or with an Ethernet crossover cable.

Element Manager access is also supported through a Citrix server.

Startup Profile

The Startup Profile enables an experienced administrator to customize a template with common BCM system parameters. This template can be used to quickly configure a single system or multiple systems.

You create the Startup Profile using the Startup Profile template (a Microsoft Excel template). You then use a USB storage device to transfer the Startup Profile data to the BCM main unit.

Loading the Startup Profile adds approximately 5 minutes to the time for the BCM system to boot.

To use the Startup Profile template, you need the following:

- a computer with a USB port
- Microsoft Excel 2000 or later
- the Nortel BCM 4.0 Startup Profile template (Microsoft Excel template)

If you do not have the Startup Profile template on your computer, you can get a copy from the BCM web page (Administrator Applications) on the BCM main unit.

- a portable USB storage device compatible with USB 1.1 (formatted for FAT32)



Note: The Startup Profile is not available for BCM1000 systems.

Chapter 3

Physical installation

This chapter provides the following installation procedures:

- [“Mounting a BCM main unit and expansion unit” on page 17](#)
- [“Connecting the expansion unit to the main unit” on page 21](#)
- [“Installing the MBMs” on page 21](#)
- [“Connecting the MBM wiring” on page 24](#)
- [“Powering up the BCM system” on page 29](#)
- [“Connecting the data networking hardware” on page 30](#)
- [“Unpacking, placing, and wiring telephone hardware” on page 31](#)

Mounting a BCM main unit and expansion unit

Before you mount a BCM main unit or expansion unit, you must decide how you want to mount the units. The main unit and expansion unit are typically mounted in the same manner. Nortel provides three methods of mounting the BCM units:

- rack-mount
- wall-mount
- desktop-mount

Make sure that the expansion unit is installed close enough to the main unit so that the supplied 5 m (16 ft) expansion cable can be connected between the expansion unit and main unit.

Refer to the chapters “Installing a main unit” and “Installing an expansion unit” in the *BCM200/400 4.0 Installation and Maintenance Guide* for more detailed information.

Installing a BCM unit in a rack

To rack-mount a BCM unit (main unit or expansion unit), you need the rack-mount kit included with the main unit.



Caution: When installing a unit in a rack, do not stack units directly on top of one another in the rack. Fasten each unit to the rack with the appropriate mounting brackets. Mounting brackets cannot support multiple units.

Use the following procedures to install a BCM unit in a rack:

- [“To attach the rack-mount brackets” on page 18](#)
- [“To mount a BCM unit in an equipment rack” on page 18](#)

To attach the rack-mount brackets



6 minutes/unit

- 1 Place the BCM unit on a flat, clean surface.
- 2 Align the screw holes between the BCM unit and one of the rack-mount brackets.
- 3 Fasten the bracket to the BCM unit using four screws. Refer to [Figure 4](#).



Caution: Use only the screws supplied with the rack-mount bracket. Other screws can damage the unit.

- 4 Repeat steps 2 and 3 for the other rack-mount bracket.
- 5 If the BCM system has an expansion unit, attach the rack-mount brackets to the expansion unit in the same way as the main unit.

Figure 4 Attach the rack-mount bracket to the BCM400 main unit

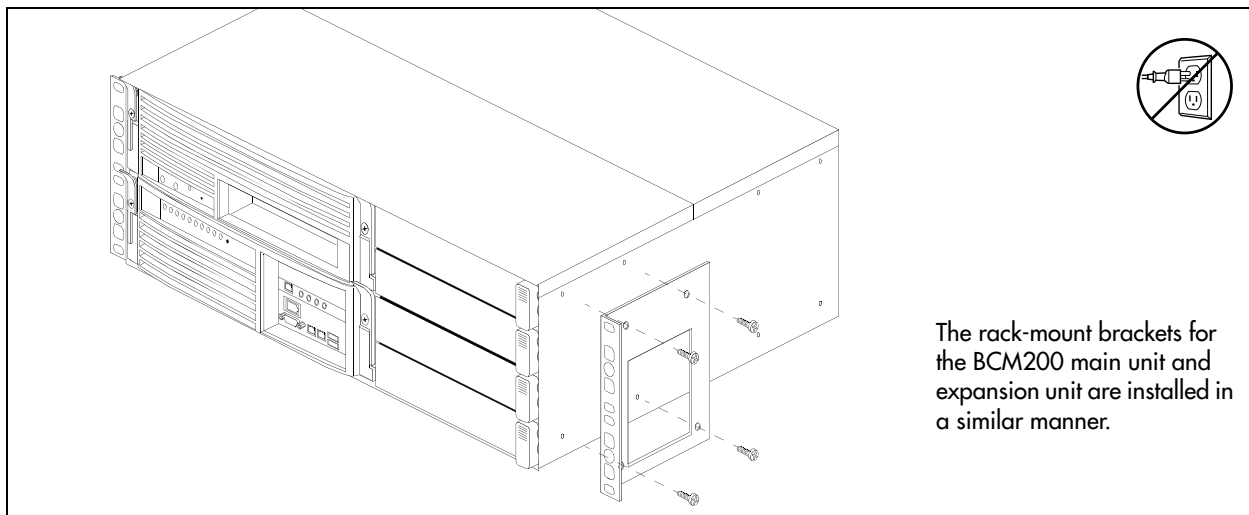

To mount a BCM unit in an equipment rack



6 minutes/unit

- 1 Determine the location in the rack where you want to install the BCM unit.
- 2 Position the BCM unit in the rack. Have an assistant hold the BCM unit.
- 3 Align the holes in the rack-mount bracket with the holes in the equipment rack rails.
- 4 Fasten the rack-mount brackets to the rack using four screws (see [Figure 5](#)).

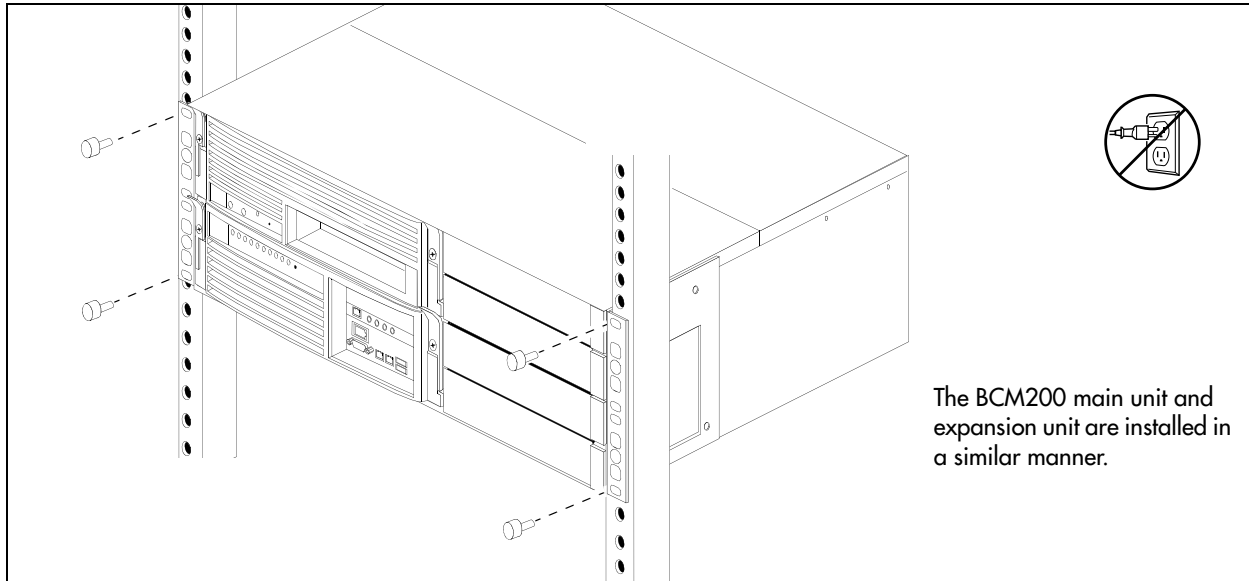
Figure 5 Fasten the BCM400 main unit to an equipment rack

- 5** If the BCM system has an expansion unit, mount the expansion unit in the same way as the main unit.

Installing a BCM unit on a wall

To wall-mount a BCM unit (main unit or expansion unit), you need the optional wall-mount kit (NTAB3422).

To install a BCM unit on a wall



12 minutes/unit

- 1** Mark the location of the plywood backboard on the wall using a pencil. Use a ruler and bubble-level to check that the plywood backboard is level with respect to the wall.
- 2** Mount the plywood backboard securely to the wall.
- 3** Mark the location of the wall-mount bracket holes on the plywood backboard.
 - a** Use the wall-mount bracket as a template.
 - b** Use a bubble-level to check that the wall-mount bracket is level with respect to the plywood backboard.
- 4** Install four #10 x 2.5 cm (#10 x 1 in.) round-head wood screws in the backboard (supplied).
 - a** Do not tighten the screws heads against the backboard. Leave approximately 0.5 cm (0.25 in.) of the screw exposed from the backboard.
 - b** Perform a trial installation of the wall-mount bracket on the plywood backboard. Ensure the wood screw heads seat in the wall-mount bracket slots. If the wood screws are too tight, loosen until the screw heads fit fully in the slots.
 - c** Ensure that the wall-mount bracket is level with respect to the plywood backboard.
 - d** Remove the wall-mount bracket.

- 5 Align the screw holes on one side of the BCM unit with the wall-mount bracket.



Note: The bracket suspends the BCM unit on the wall. Consider the direction you want the MBMs to face, left or right, when you choose the side on which to install the bracket.

- 6 Fasten the wall-mount brackets securely to the BCM unit using the screws provided. Refer to Figure 6.



Caution: Use only the screws supplied with the wall-mount bracket kit (NTAB3422). Other screws can damage the unit.

Figure 6 Attach the wall-mount bracket to the BCM400 main unit

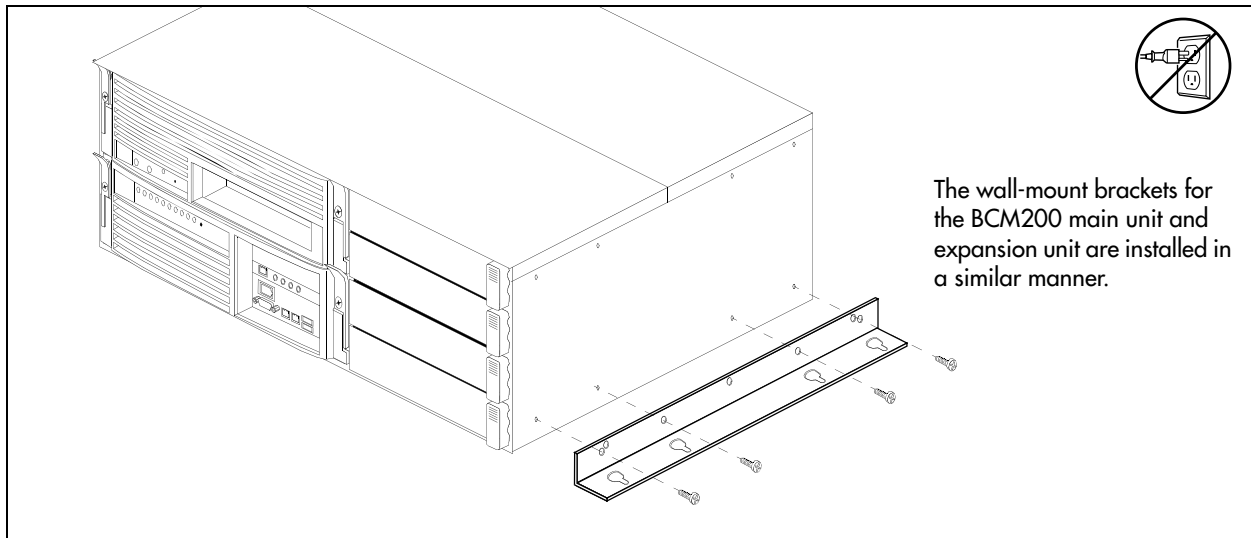

- 7 Hang the BCM unit on the backboard screws. Make sure the BCM unit is level. Ensure the wood screw heads seat fully into the wall-mount bracket slots.
- 8 Tighten the wood screws against the wall-mount bracket.
- 9 If the BCM system has an expansion unit, mount the expansion unit in the same way as the main unit.

Installing a BCM unit on a flat surface

Follow this procedure to install a BCM unit (main unit or expansion unit) on a flat surface.



Caution: Do not place anything directly on top of the BCM main unit.

To install a BCM unit on flat surface

 10 minutes/unit

- 1 Attach four rubber feet to the corners on the bottom of the BCM unit.
- 2 Position the unit on the table or shelf. Make sure you leave enough space around the unit for ventilation and access to the cables and MBMs.
- 3 If the BCM system has an expansion unit, mount the expansion unit in the same way as the main unit.

Connecting the expansion unit to the main unit

After the main unit and expansion unit have been installed, use the supplied DS256 cable to connect the expansion unit to the main unit.

Refer to the chapter “Installing an expansion unit” in the *BCM200/400 4.0 Installation and Maintenance Guide* for more detailed information.

To connect the expansion unit to the main unit

 1 minutes

- 1 Plug one end of the cable into the DS256 connector on the expansion unit (see [Figure 7](#)).
- 2 Plug the other end of the cable into the DS256 connector on the main unit (see [Figure 7](#)).

Figure 7 Main unit connected to expansion unit

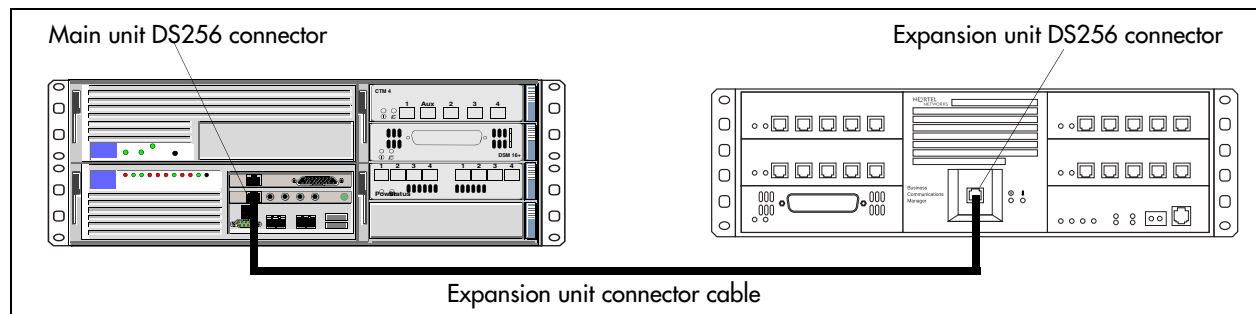

Warning: The timing in the BCM system is critical. Use the correct length cable as supplied with the expansion unit. The system will not work properly if you connect the BCM expansion unit using a cable that varies in length.

Installing the MBMs

Refer to the chapter “Installing a media bay module (MBM)” in the *BCM200/400 4.0 Installation and Maintenance Guide* for more detailed information.



Warning: Install DTMs in the BCM main unit only. DTMs do not function if installed in the BCM expansion unit. If there are no empty MBM bays in the BCM main unit, move MBMs to the expansion unit to provide space for the DTMs.

Use [Table 6](#) and [Table 7](#) to set the DIP switches for the MBMs.

Table 6 Possible trunk MBM DIP switch settings

DS30 bus #	Trunk MBM positioning									DIP switch settings						Offsets						
	4x16 Offsets 0,1, 2, 3 Line Exten.		DDIM Offset 0	DTM Offset 0	CTM4 Offsets 0, 1, 2, 3	CTM8 Offsets 0, 1, 2	GATM Offsets 0, 1, 2, 3	GATM8 Offsets 0, 1, 2	BRI Offsets 0, 1, 2, 3	1 2 3 4 5 6 (offset) (DS30 #)												
	0	Picks up ch. #3	0	Picks up ch. #3	0	0	0	0	0	0	0	0	0	0	0		0	0	0			
2	0	Picks up ch. #3	0	Picks up ch. #3	0	0	0	0	0	0	0	0	0	0	0	0	0	0	0			
	1					1	1	1	1	1	1	1	1	1	1	1	1	1	1	1	1	
	2					2	2	2	2	2	2	2	2	2	2	2	2	2	2	2	2	2
	3					3	3	3	3	3	3	3	3	3	3	3	3	3	3	3	3	3
3	0	Picks up ch. #4	0	Picks up ch. #4	0	0	0	0	0	0	0	0	0	0	0	0	0	0	0			
	1					1	1	1	1	1	1	1	1	1	1	1	1	1	1	1		
	2					2	2	2	2	2	2	2	2	2	2	2	2	2	2	2	2	
	3					3	3	3	3	3	3	3	3	3	3	3	3	3	3	3	3	3
4	0	Picks up ch. #5	0	Picks up ch. #5	0	0	0	0	0	0	0	0	0	0	0	0	0	0	0			
	1					1	1	1	1	1	1	1	1	1	1	1	1	1	1	1		
	2					2	2	2	2	2	2	2	2	2	2	2	2	2	2	2	2	
	3					3	3	3	3	3	3	3	3	3	3	3	3	3	3	3	3	3
5	0	Picks up ch. #6	0	Picks up ch. #6	0	0	0	0	0	0	0	0	0	0	0	0	0	0	0			
	1					1	1	1	1	1	1	1	1	1	1	1	1	1	1	1		
	2					2	2	2	2	2	2	2	2	2	2	2	2	2	2	2	2	
	3					3	3	3	3	3	3	3	3	3	3	3	3	3	3	3	3	3
6	0	Picks up ch. #7	0	Picks up ch. #7	0	0	0	0	0	0	0	0	0	0	0	0	0	0	0			
	1					1	1	1	1	1	1	1	1	1	1	1	1	1	1	1		
	2					2	2	2	2	2	2	2	2	2	2	2	2	2	2	2	2	
	3					3	3	3	3	3	3	3	3	3	3	3	3	3	3	3	3	3
7*	Not supported		Not supported		0	0	0	0	0	0	0	0	0	0	0	0	0	0	0			
						1	1	1	1	1	1	1	1	1	1	1	1	1	1			
						2	2	2	2	2	2	2	2	2	2	2	2	2	2			
						3	3	3	3	3	3	3	3	3	3	3	3	3	3			

MBM set to offset 0
 MBM set to offset 1
 MBM set to offset 2
 MBM set to offset 3

Each shaded square represents the amount of the DS30 buses, and the offset, which the MBM requires.

* If your system is configured with a 3/5 DS30 split, DS30 bus 7 is not available to MBM and DS30 bus 6 is not supported for the 4x16 and DDIM.

Table 7 Possible station MBM DIP switch settings

DS30 bus #	Station MBM positioning				DIP switch settings (Single density)						DIP switch settings (Double density)						Offsets	
	DSM16+ Offsets 0, 1 SDDFDD		DSM32+ Offsets 0, 1 SDDFDD		ASM 8/ GASM8 Offsets 0, 1, 2, 3	1	2	3	4	5	6	1	2	3	4	5		6
						(offset)						(DS30 #)						
2	0	0	0	0	0***	on	on	on	on	on	on	off	on	on	on	on	on	0
					1	on	on	off	on	on	on	off	on	off	on	on	on	1
	1	2	on	off	on	on	on	on	off	off	on	on	on	on	2			
		3	on	off	off	on	on	on	off	off	off	on	on	on	3			
3	0	0	0	0	0	on	on	on	on	on	off	off	on	on	on	on	off	0
					1	on	on	off	on	on	off	off	on	off	on	on	off	1
	1	2	on	off	on	on	on	off	off	off	on	on	on	off	2			
		3	on	off	off	on	on	off	off	off	off	on	on	off	3			
4	0	0	0	0	0	on	on	on	on	off	on	off	on	on	on	off	on	0
					1	on	on	off	on	off	on	off	on	off	on	off	on	1
	1	2	on	off	on	on	off	on	off	off	on	on	off	on	2			
		3	on	off	off	on	off	on	off	off	off	on	off	on	3			
5	0	0	0	0	0	on	on	on	on	off	off	off	on	on	on	off	off	0
					1	on	on	off	on	off	off	off	on	off	on	off	off	1
	1	2	on	off	on	on	off	off	off	off	on	on	off	off	2			
		3	on	off	off	on	off	off	off	off	off	on	off	off	3			
6	0	0	0	0	0	on	on	on	off	on	on	off	on	on	off	on	on	0
					1	on	on	off	off	on	on	off	on	off	off	on	on	1
	1	2	on	off	on	off	on	on	off	off	on	off	on	on	2			
		3**	on	off	off	off	on	on	off	off	off	off	on	on	3			
7*	0	0	0	0	0	on	on	on	off	on	off	off	on	on	off	on	off	0
					1	on	on	off	off	on	off	off	on	off	off	on	off	1
	1	2	on	off	on	off	on	off	off	off	on	off	on	off	2			
		3**	on	off	off	off	on	off	off	off	off	off	on	off	3			

MBM set to offset 0
 MBM set to offset 1
 MBM set to offset 2
 MBM set to offset 3

Each shaded square represents the amount of the DS30 bus, and the offset, which the MBM requires.

* If your system is configured with a 3/5 DS30 split, DS30 7 is not available to MBMs.

** ASM MBMs always use the single density DIP switch settings, with the appropriate offset.

To install MBMs



4 minutes/MBM



Caution: Only install the MBMs when the system is powered down.

- 1 Ensure that the switches on the MBM are set correctly (see [Table 6](#) and [Table 7](#)).
In the case of FEM MBMs, the switches activate the front ports. Ensure that the switches accurately reflect the ports you require.
- 2 Select an open MBM bay.
- 3 With the face of the MBM facing toward you, insert the MBM into the open bay.
- 4 Push the MBM completely into the unit. You will hear a click when the MBM is firmly seated in the bay.
- 5 Repeat steps 2 to 4 for each MBM you want to install.

Connecting the MBM wiring

Refer to the chapter “Installing a media bay module (MBM)” in the *BCM200/400 4.0 Installation and Maintenance Guide* for more detailed information.

This section describes how to wire the cables that connect to the station and trunk MBMs.

- Station MBMs have one (ASM, DSM16, 4x16) or two (DSM32) 50-pin amphenol connectors (25-pair cables).
- Trunk MBMs (CTM4, CTM8, 4x16, DTM, and BRI) connect to central office trunks using RJ-type jacks. However, the GATM4 and GATM8 have a 50-pin amphenol connector (25-pair cable).



Warning: Use only qualified persons to service the system.

The installation and service of this unit must be performed by service personnel with the appropriate training and experience. Service personnel must be aware of the hazards of working with telephony equipment and wiring. They must have experience in techniques that minimize any danger of shock or equipment damage.

Leakage currents: Service personnel must be alert to the possibility of high leakage currents becoming available on metal system surfaces during power line fault events on network lines. These leakage currents normally safely flow to Protective Earth ground through the power cord. However, if the AC power is unplugged prior to disconnecting the cables from the front of the base function tray, this hazard can occur.

System shutdown: You must disconnect the MBM cables from the system before disconnecting the power cord from a grounded outlet.

System startup: You must reconnect the power cords to a grounded outlet before reconnecting the cables to the MBMs.

**Danger: Electrical shock hazards**

Electrical shock hazards from the telecommunications network and AC mains are possible with this equipment. To minimize risk to service personnel and users, the BCM system must be connected to an outlet with a third wire ground. In addition, all unused slots must have blank faceplates installed. The covers on all units must be in place at the completion of any servicing.

**Warning: Electrical shock warning.**

The BCM MBMs have been safety approved for installation into BCM main units and expansion units. It is the responsibility of the installer and user to ensure that installation of the BCM hardware does not compromise existing safety approvals.

Before you open the BCM main unit or expansion unit ensure that the network cables are unplugged and the unit is disconnected from the AC power source.

Station MBMs: The ports on these MBMs are meant to be connected only to approved digital telephones and peripherals with the proper cables on a protected internal wiring system.

Do not connect any telephones to wiring that runs outside of the building.

To connect the DTM, CTM, BRIM, or 4x16 MBMs

15 minutes

- 1 On the front of the MBM, locate the RJ-48C jack (DTM), RJ-45 jack (BRIM), or the RJ-11 jacks (CTM and 4x16).
- 2 Connect one end of the cable to the demarcation blocks of the building (see [Figure 8](#), [Figure 9](#), or [Figure 10](#) for the appropriate pin-out).

Figure 8 DTM RJ-48C wiring array

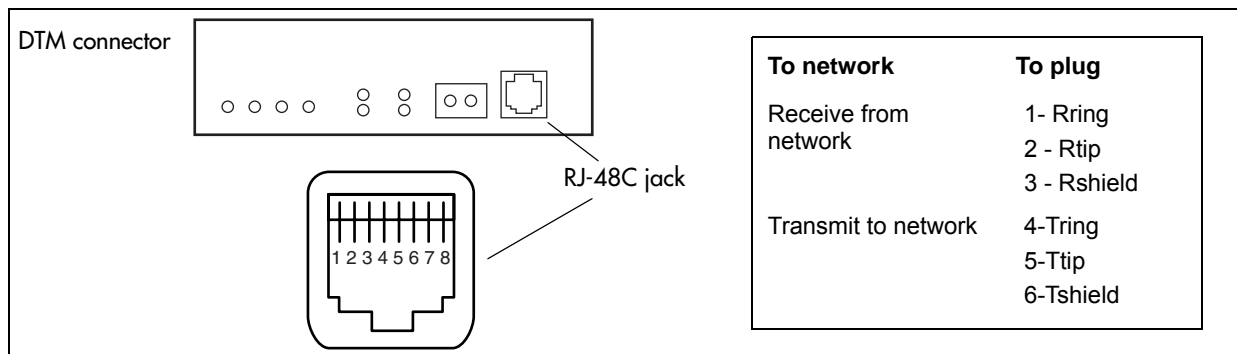

Figure 9 CTM RJ-11 wiring array

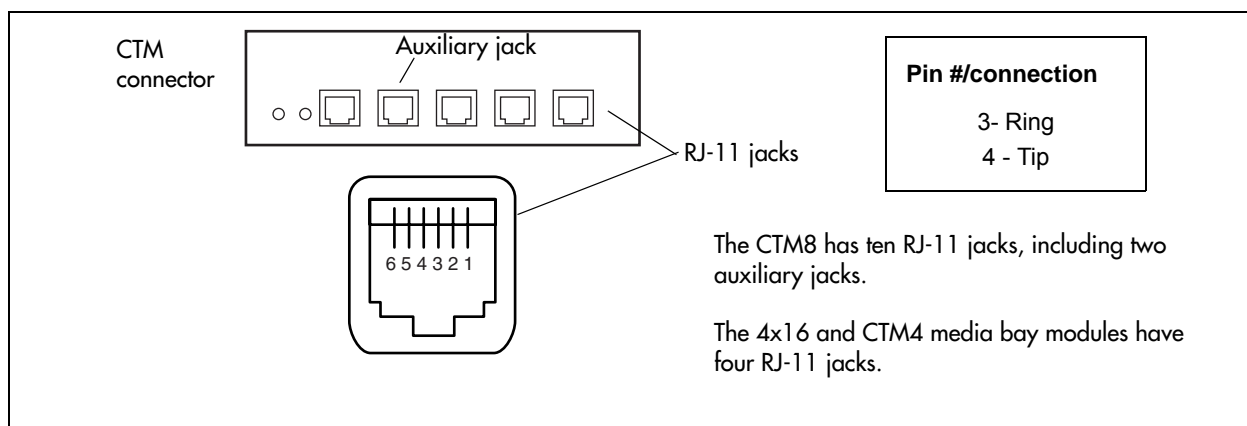
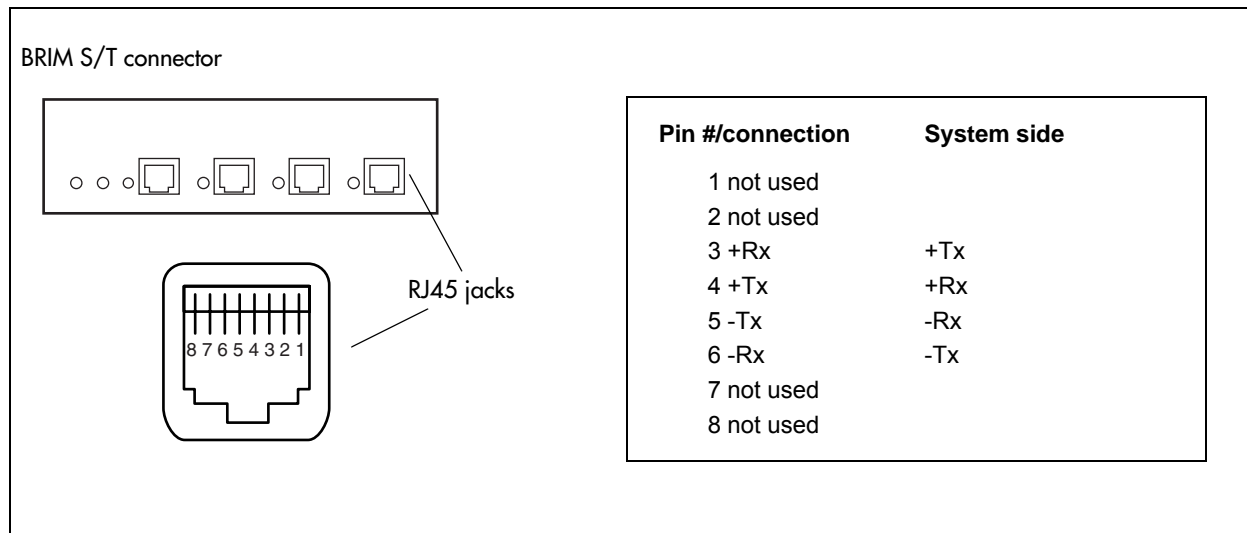

Figure 10 BRIM S/T RJ-45 wiring array



Warning: If you are using a service provider channel service unit (CSU), you must disable the BCM system internal CSU.

All MBMs have an auxiliary jack (the CTM8 has two). Do not attempt to plug digital equipment into this jack.



Warning: The BRIM S/T must only be connected to an NT1 provided by the service provider. The NT1 must provide a Telecommunication Network Voltage (TNV) to Safety Extra Low Voltage (SELV) barrier.

- 3 Insert the connector into the jack on the MBM.

To connect the GATM



2 minutes

- 1 Connect one end of the cable to the amphenol connector on the front of the MBM.
- 2 Connect the other end of the cable to the demarcation blocks of the building.

To connect the DSM16, DSM32, ASM8, GASM8, or 4x16 MBMs



15 minutes

- 1 Connect 16 wire pairs from the amphenol connector to the local connecting blocks so they connect to the 16 stations you want connected to this MBM (see [Table 8](#)).

Table 8 ASM and DSM wiring chart (Sheet 1 of 2)

Pin	Wire color	Port	¹ DSM Set #	² DSM Set #	ASM Set #
26	White-Blue	X01	1	17	1
1	Blue-White	X01	1	17	1
27	White-Orange	X02	2	18	2
2	Orange-White	X02	2	18	2
28	White-Green	X03	3	19	3
3	Green-White	X03	3	19	3
29	White-Brown	X04	4	20	4
4	Brown-White	X04	4	20	4
30	White-Slate	X05	5	21	5
5	Slate-White	X05	5	21	5
31	Red-Blue	X06	6	22	6
6	Blue-Red	X06	6	22	6
32	Red-Orange	X07	7	23	7
7	Orange-Red	X07	7	23	7
33	Red-Green	X08	8	24	8
8	Green-Red	X08	8	24	8
34	Red-Brown	X09	9	25	–
9	Brown-Red	X09	9	25	–
35	Red-Slate	X10	10	26	–
10	Slate-Red	X10	10	26	–
36	Black-Blue	X11	11	27	–

Table 8 ASM and DSM wiring chart (Sheet 2 of 2)

Pin	Wire color	Port	¹ DSM Set #	² DSM Set #	ASM Set #
11	Blue-Black	X11	11	27	–
37	Black-Orange	X12	12	28	–
12	Orange-Black	X12	12	28	–
38	Black-Green	X13	13	29	–
13	Green-Black	X13	13	29	–
39	Black-Brown	X14	14	30	–
14	Brown-Black	X14	14	30	–
40	Black-Slate	X15	15	31	–
15	Slate-Black	X15	15	31	–
41	Yellow-Blue	X16	16	32	–
16	Blue-Yellow	X16	16	32	–
For ASM only					
34-50 9-25	no connection				
For DSM only					
42-50 17-25	no connections				
¹ Single connector, or bottom connector on DSM 32/32+ modules.					
² Upper connector on DSM 32/32+ modules.					

- 2** Install the telephones and peripheral equipment (if it is a new system):
 - a** Attach the cables for the telephones to the connecting blocks.
 - b** Install the telephones.
- 3** Plug the female amphenol connector into the interface on the front of the MBM.
- 4** Set up any mobile system you are using.
 - Ensure the base stations are correctly installed and connected to the appropriate MBMs on the BCM system. In the case of the Wireless LAN IP phone system, ensure that the access point is correctly set up to connect to the BCM system LAN or WAN.
 - Configure and register the handsets according to the instructions provided for each type of system.

Wiring the FEM

A fiber expansion module (FEM) allows you to upgrade from a Norstar system to a BCM system by reusing the Norstar MBMs. The MBMs connect to the FEM using the same fiber cable that connected them to the Norstar fiber expansion card.



Warning: Handling optical fiber cables.

If the cable is too long, ensure that it is coiled correctly using the fiber spool. Coil excess fiber cable carefully around the spool provided. Do not bend the cable around any tight corners. Bends in the fiber cable must not be less than 100 mm in diameter. Place the fiber cable spool into a slot at the back of the cable trough in the Norstar module.

To connect the fiber cables



2 minutes/MBM

- 1 Ensure the BCM system is powered up and functional.
- 2 Connect the fiber cables from the Norstar MBMs to the jacks on the FEM.



Note: The DIP switch settings you chose determine which FEM ports are available. If you enable all six FEM ports, the BCM system has no more DS30 resources available. Therefore, you cannot connect more MBMs to the system.

- a Connect the Norstar Line Modules to the FEM beginning at fiber port 1.
 - b Connect Norstar Extension Modules to the FEM beginning at fiber port 6.
- 3 Change the DN records in Element Manager or change the set wiring, as required, to match your system.



Note: If you connect a Norstar station module amphenol cable directly to a DSM, you do not have to modify the wiring connections. Ensure you select the correct DS30 number.

Powering up the BCM system

Refer to the chapter “Connecting the cables” in the *BCM200/400 4.0 Installation and Maintenance Guide* for more detailed information.



Caution: The BCM system is available in North American and International versions. Ensure that the power supply is correct for your location. The BCM200 and BCM400 systems have standard power supplies and redundant power supplies that adjust automatically to the required voltage.

To power up the BCM system



Note: If you are using the Startup Profile to configure the BCM system, insert the USB storage device (containing the Startup Profile file) into the USB port on the main unit before powering up the system.

- 1 Connect the BCM main unit power cord to an electrical outlet that is a non-switchable, third-wire ground AC outlet.

If you use a power bar, plug the power cords into the power bar and connect the power bar to the AC outlet.

- 2 Connect the BCM expansion unit power cord to an electrical outlet that is a non-switchable, third-wire ground outlet.



Danger: Do not fasten the BCM main unit or expansion unit power supply cords to any building surface.

- 3 Turn on the power switch located on the BCM main unit and expansion unit.
The BCM system powers up.

Connecting the data networking hardware

Refer to the chapter “Connect the cables” in the *BCM200/400 4.0 Installation and Maintenance Guide* for more detailed information.

This section describes how to connect network cards to the BCM system.



Warning: If the default IP address creates a network conflict, you must change the IP address of the BCM system before you connect to the network. Refer to [“Connecting to the BCM system” on page 33](#) for detailed instructions about connecting to the BCM system.

The data networking hardware (MSC) is installed in the BCM main unit at the factory. All systems have dual embedded Ethernet interfaces. Some models come with an embedded V.90 modem. WAN cards and modems are ordered separately.



Note: Your BCM system might have a different WAN card than the one described. Refer to the documentation that came with your WAN card.

To connect the BCM system to the WAN

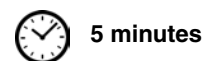

- 1 Ensure the system is powered up before connecting this cable.
- 2 Do one of the following:

- To connect the WAN card using the RJ-48C connector, insert the wide area network (WAN) cable into the RJ-48C jack on the WAN card (see [Figure 1 on page 13](#) and [Figure 2 on page 14](#)).
- To connect the WAN card using the DB26 connector, use an adapter cable to connect the wide area network (WAN) cable to the DB26 connector on the WAN card. These adapter cables are available from your BCM supplier (see [Figure 1 on page 13](#) and [Figure 2 on page 14](#)).

Refer to the *BCM200/400 4.0 Installation and Maintenance Guide* for information on adapter cable pin-outs.

To connect the modem



- 1 Ensure the system is powered up before connecting this cable.
- 2 Insert a PSTN line into the line jack on the modem interface (see [Figure 1 on page 13](#) and [Figure 2 on page 14](#)).

Refer to the *BCM200/400 4.0 Installation and Maintenance Guide* for information on adapter cable pin-outs.

Unpacking, placing, and wiring telephone hardware

Refer to the chapter “Installing telephones and peripherals” in the *BCM200/400 4.0 Installation and Maintenance Guide* for more detailed information.

The following telephones are supported:

- Digital Phone 7000, 7100, 7208, 7316, 7316E, 7324
- Digital Phone 7406 Cordless Telephone system
- IP Phone 2001, 2002, 2004, 2007
- IP Phone 1120E, 1140E
- i2050 software phone
- WLAN handsets 2210, 2211, 2212
- IP Audio Conferencing Unit (ACU) 2033

To install telephones



- 1 Open the box for each telephone and check that you have all of the components listed below:
 - telephone set
 - power supply and power supply cable
 - telephone cable
 - installation instructions
- 2 Visually inspect the components for any damage.
- 3 Install the telephones as shown in the included installation instructions.

- 4 Label the telephone with customer-supplied information. Note the location, wall jack identifier, and phone number for punch downs and BCM software commissioning.

To install optional telephony equipment



5 minutes

This includes auxiliary ringer, external paging system, and external music source.

The indicated time includes only the wiring of these items, not the physical installation.

- 1 Use the installation instructions included with the optional telephony hardware to install the equipment.
- 2 Connect the telephony equipment jack to the appropriate output on the MSC faceplate of the main unit (see [Figure 1 on page 13](#) and [Figure 2 on page 14](#)).



Warning: The optional telephony equipment must not be connected to exposed plant.

Chapter 4

Connection and configuration procedures

The initial configuration defines your BCM system to the network. It also gives the system a unique identity and initial parameters. From that point, you can continue with the specific configurations for your system.

This chapter provides the following connection and configuration procedures:

- [“Connecting to the BCM system” on page 33](#)
- [“Downloading from the BCM web page” on page 36](#)
- [“Generating a software keycode” on page 37](#)
- [“Configuring the BCM system parameters” on page 37](#)
- [“Configuring the MBMs” on page 42](#)
- [“Customizing other parameters” on page 43](#)

For more information about installing the BCM system (such as wiring charts and cable diagrams), refer to the *BCM200/400 4.0 Installation and Maintenance Guide*.

Connecting to the BCM system

Refer to the chapter “Initialize the system” in the *BCM200/400 4.0 Installation and Maintenance Guide* for more detailed information.

If you can use the default IP address, you can connect the BCM system to the LAN. This enables you to configure the BCM system, through Element Manager, from any PC connected to the LAN.

If you can connect through a LAN connection, proceed to [“Downloading from the BCM web page” on page 36](#).



Warning: Before using the default address on your network, check with your system administrator. If this address conflicts with the LAN settings, you can cause network damage if you connect to the network without changing the IP address.

If you must change the IP address (due to a conflict with your network), connect to the BCM system using an Ethernet crossover cable (see [“Connecting through the Ethernet crossover cable” on page 34](#)), through the serial port (see [“Connecting through the serial port” on page 34](#)), or change the IP address using Telnet Administration.

Connecting through the Ethernet crossover cable

Use the following two procedures to connect the Ethernet crossover cable and configure your computer to connect to the BCM system.

To connect the Ethernet crossover cable

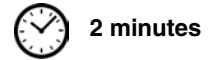

- 1 Shut down your computer.
- 2 Attach one end of the Ethernet crossover cable to LAN port 1 on the BCM main unit.
- 3 Connect the other end of the cable to the network interface card on your computer.
- 4 Start your computer.

To configure your computer



Note: The steps below may differ slightly depending on the operating system of your computer. The task in this section is to specify IP and subnet addresses for the computer.

- 1 From the **Start** menu, choose **Settings** and then choose **Control panel**.
- 2 Double-click the **Network** icon.
- 3 Select your TCP/IP adapter, and then click the **Properties** button.
- 4 Click the **IP Address** tab.
- 5 Click the **Specify an IP address** option.
- 6 In the **IP Address** field, enter the IP address of the BCM system (if using default IP, enter 10.10.10.2).
- 7 In the **Subnet Mask** field, enter the subnet mask of the BCM system (if using default IP, enter 255.255.255.0).
- 8 Click **OK**.
- 9 Click **OK**.

Your computer is now configured to connect to the BCM system.

Connecting through the serial port

You can also connect to the BCM system through the serial port using a null modem cable. You can then change the IP address of the BCM system and perform other basic configuration tasks. You can use Element Manager to perform more detailed configuration of your system.

You must use a null modem cable connection to the BCM main unit if the default IP address is not compatible with your LAN or WAN network.

To connect through the serial port



10 minutes

- 1 Attach the null modem cable to the serial port on the BCM main unit.



Note: The location of the transmit (TX) and receive (RX) pins on your terminal can vary. Refer to your terminal or computer documentation to confirm pin locations.

- 2 Attach the other end of the null modem cable to the serial port on the terminal or computer.
- 3 Ensure that the BCM main unit and your terminal or computer are turned on.
- 4 Access the BCM main unit using one of the following methods:
 - a If using a terminal emulation program (Hyperterminal), attach a configuration computer to the BCM main unit serial port (recommended method).
 - b If you are accessing the BCM main unit through your local area network through SSH (secure socket shell), use the default IP address 10.10.10.1.
- 5 When prompted for a **User ID**, type:

```
nnadmin
```
- 6 When prompted for a **Domain**, press <ENTER>.
- 7 When prompted for a **Password**, type:

```
PlsChgMe!
```
- 8 The Configuration main menu screen appears. Refer to [Figure 11](#).

Figure 11 Configuration main menu screen

```

root@BCM95: /CLI
-----
..... BUSINESS COMMUNICATION MANAGER 4.0 .....
-----

                QUICK CONFIGURATION

=====
1-->System name                :BCM95
2-->LAN1 IP address settings(static/DHCP) :Static
3-->LAN1 IP address            :172.17.3.95
4-->LAN1 IP subnet mask        :255.255.240.0
5-->Default gateway            :172.17.1.1
6-->Logout
7-->Reboot BCM System(does not restart telephony)

=====

***** Change Here *****

ENTER-
      1-->System name                2-->LAN1 IP address settings
      3-->LAN1 IP address            4-->LAN1 IP subnet mask
      5-->Default gateway            6-->Logout/Exit
      7-->Reboot
Make Selection [1 2 3 4 5 6 7 ] : █

```



Note: If the Initialization Menu screen appears instead of the Main Menu shown above, your BCM system is not initialized correctly.

- 9 Enter the number of the parameter you want to configure.
-



Warning: Changing this information on an existing system completely erases the telephony programming and disables the telephony system. It also reboots the BCM system.

Downloading from the BCM web page

After your computer is connected to the BCM system, either through an Ethernet crossover cable or through a LAN connection, you can download Element Manager and the Startup Profile template from the Administrator Applications area of the BCM web page.

To access the BCM web page

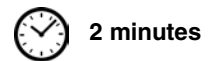

- 1 Open a web browser and enter the BCM system IP address.
The Enter Network Password dialog box opens.
- 2 Enter the username and password (defaults are shown below):
Username: **nnadmin**
Password: **PlsChgMe!**
- 3 Click **OK**.
The Welcome to BCM web page opens.

To download and install BCM Element Manager

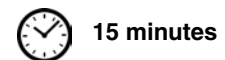

- 1 Access the BCM web page (see [“To access the BCM web page”](#) on page 36).
- 2 On the **Welcome to BCM** web page, click **Administrator Applications**.
The Administrator Applications page opens.
- 3 On the **Administrator Applications** page, click **BCM Element Manager**.
The BCM Element Manager panel opens.
- 4 Read the information on this panel.
- 5 Click **Download Element Manager** on the right side of the screen, and follow the instructions to download.
- 6 After BCM Element Manager has finished downloading, double-click the application and follow the instructions to install.

To download the Startup Profile template

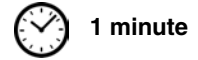

- 1 Access the BCM web page (see “[To access the BCM web page](#)” on page 36).
- 2 On the **Welcome to BCM** web page, click **Administrator Applications**.
The Administrator Applications page opens.
- 3 On the **Administrator Applications** page, click **Startup Profile Template**.
The Startup Profile Template panel opens.
- 4 Read the information on this panel.
- 5 Click **Download Startup Profile Template** on the right side of the screen, and follow the instructions to download.

Generating a software keycode

You require a keycode to enable software features your BCM system. You receive only one keycode whether you purchase one feature or a bundle of features. You can load a keycode using Element Manager, Startup Profile, or Telset Administration.

To generate a keycode, you require an authorization code for each feature you purchase.

For example, if you have one feature, you receive one authorization code and you will generate one keycode. If you purchase four features, you receive four authorization codes, however, you will still generate only one keycode.

To generate a keycode through the Nortel Keycode Retrieval System (KRS), you require:

- Username and password for the KRS (<http://www.nortel.com/servsup/krs>)
- BCM 4.0 feature authorization code for each feature
- BCM 4.0 system ID

For more information on keycodes, refer to the *Keycode Installation Guide*.

Configuring the BCM system parameters

Refer to the chapter “Configuring the BCM system” in the *BCM200/400 4.0 Installation and Maintenance Guide* for more detailed information.

This section provides information on configuring the basic BCM system parameters (see [Table 9](#)). You can configure the basic parameters using the Startup Profile template or Element Manager. After configuring the basic parameters, you can configure more advanced parameters using Element Manager.

Table 9 BCM system parameters (Sheet 1 of 2)

Parameters	Element Manager	Startup Profile	Telset Administration
Keycode	Configuration > System > Keycodes	Keycode	Feature 9*8 > Feature codes
IP address: <ul style="list-style-type: none"> Obtain dynamically IP address IP subnet mask 	Configuration > Resources > Network Interfaces	IP Address	Feature 9*8 > IP Address
Modem: <ul style="list-style-type: none"> Enable/disable modem 	Configuration > Resources > Network Interfaces	Modem	Feature 9*8 > Modem
System: <ul style="list-style-type: none"> Region 	Administration > Utilities > Reset > Cold Reset Telephony Services	System	Feature **PROFILE
Telephony startup: <ul style="list-style-type: none"> Template Start DN 	Administration > Utilities > Reset > Cold Reset Telephony Services	Telephony Startup	Feature **STARTUP
Voice mail: <ul style="list-style-type: none"> Attendant DN UI style Language Auto Attendant From Line To Line Number of rings 	Configuration > Applications > Voice Messaging/Contact Center	Voice Mail Startup	Feature 983
User account: <ul style="list-style-type: none"> Telset user ID (numeric) Telset password (numeric) 	Configuration > Administrator Access > Accounts and Privileges > View by Accounts tab	UserAccount	Feature 9*8 > User Accounts
System: <ul style="list-style-type: none"> System name 	Configuration > System > Identification	System	N/A
System: <ul style="list-style-type: none"> System ID 	Configuration > System > Keycodes (View ID - it is set automatically and cannot be changed)	System	N/A
Time: <ul style="list-style-type: none"> Date and Time source NTP server address Date and time Time zone 	Configuration > System > Date and Time	Time	N/A

Table 9 BCM system parameters (Sheet 2 of 2)

Parameters	Element Manager	Startup Profile	Telset Administration
DHCP server: <ul style="list-style-type: none"> • Enable/disable server • IP domain name • Primary DNS • Secondary DNS • Default gateway 	Configuration > Data Services > DHCP Server > Subnets tab	DHCP Server	N/A
IP Phones: <ul style="list-style-type: none"> • Enable registration • Enable global pwd • Global pwd • Auto-assign DNS • Advertisement logo 	Configuration > Resources > Telephony Resources	IP Telephones	N/A
SNMP Agent: <ul style="list-style-type: none"> • Enable/disable SNMP agent • Minimum security • SNMP version support 	Configuration > Administrator Access > SNMP > General tab	SNMP Agent	N/A
SNMP community: <ul style="list-style-type: none"> • Community string • Type of access 	Configuration > Administrator Access > SNMP > Community strings tab	SNMP Community	N/A
SNMP manager: <ul style="list-style-type: none"> • Manager IP address 	Configuration > Administrator Access > SNMP > General tab	SNMP Manager	N/A
User account: <ul style="list-style-type: none"> • User ID • Group • Description • Callback number 	Configuration > Administrator Access > Accounts and Privileges > View by Accounts tab	User Account	N/A

You can configure the BCM system by using either Element Manager or the Startup Profile.

To configure the BCM system using BCM Element Manager



15 minutes

- 1 Open BCM Element Manager.
- 2 From the **Network** menu, select **New Network Element** and then select **Business Communications Manager**.
- 3 Enter the BCM system IP address, the username, and password (the defaults are shown below):

IP address: **10.10.10.1**

Username: **nnadmin**

Password: **PlsChgMe!**

- 4 Click **OK**.
- 5 From the **Network Elements** folder, select the BCM system IP address.
- 6 Make sure that the correct username and password are entered.
- 7 Click **Connect**.

You are now connected to the BCM system.

- 8 Configure the required parameters (see [Table 9 on page 38](#)).

For more information on using BCM Element Manager, refer to the online Help within Element Manager.

To configure the BCM system using the Startup Profile (optional)



15 minutes



Note: The Startup Profile template uses macros to perform certain functions. You must set your Excel macro security level to medium or low to enable the macros:

- From the Tools menu, select **Macros** and then select **Security**.
 - Select **Medium** or **Low**.
 - Exit from Excel.
 - Open the Startup Profile template (in Excel).
 - Enable macros if prompted.
-

- 1 On a computer that has a USB port and Microsoft Excel, open the Startup Profile template.
If you do not have a copy of the Startup Profile template, see [“To download the Startup Profile template” on page 37](#).
- 2 Refer to the **Usage Instructions** tab for instructions about using the Startup Profile template.
- 3 Click the **StartupProfileTemplate** tab to begin entering information in the Startup Profile template.
- 4 In the Startup Profile template, enter your BCM system ID in the System ID field.
The system ID is on the box of the main unit and on the main unit itself. If you enter the wrong system ID, the Startup Profile will not work with your system.
- 5 Click the large button at the top of the Startup Profile template to save a version of the Startup Profile (.sps file) and a version of the Startup Profile editor (Excel spreadsheet) on your computer.
The filenames for the Startup Profile editor and the Startup Profile consist of the system ID followed by the appropriate extension.



Note: Never edit the Startup Profile (.sps file) directly; always use the Startup Profile editor to make changes.

- 6 In the Startup Profile editor, enter the remaining information that you want loaded onto the BCM system.

The Startup Profile editor contains explanations of the various parameters. Click the cell where you want to enter information, and the Help text appears.

You can specify which parameters to load onto your system by selecting **Apply** for the parameters you want to load. If you do not want to load certain parameters, select **Ignore**.

- 7 When you have entered all the information, click the large button at the top of the Startup Profile template to save a version of the Startup Profile (.sps file) and a version of the Startup Profile editor (Excel spreadsheet) on your computer.
- 8 Exit from Microsoft Excel.
- 9 Insert the USB storage device into the USB port of the computer.
- 10 Copy the Startup Profile (.sps file) to the root directory of the USB storage device.
- 11 If you want to load your keycode using the Startup Profile, copy the keycode file to the root directory of the USB storage device.

The name of the keycode file on the USB storage device must exactly match the filename you entered in the Startup Profile editor.

- 12 Remove the USB storage device from the USB port of the computer.

The Startup Profile is now stored on the USB storage device.

- 13 Insert the USB storage device into the USB port of the BCM main unit before the BCM system is powered up.

The BCM system automatically detects the Startup Profile file and loads the information during the bootup sequence. Loading the Startup Profile increases the time for the BCM system to boot depending on the selected parameters. See [Table 10](#) for details about Startup Profile times and LED status.



Warning: Do not use the Startup Profile on a functional BCM system. The current parameter values will be replaced with those defined in the Startup Profile.



Note: The Startup Profile functions only on a BCM system that does not have a keycode file applied. After a keycode file is applied, the Startup Profile does not function. This condition prevents overwriting of the parameters of a configured system.

To re-apply the Startup Profile, remove the applied keycode file by returning the system to factory defaults using the BIT tool.

For more information on using the Startup Profile, refer to the *BCM200/400 4.0 Installation and Maintenance Guide*.

Startup Profile times and LED sequence

Table 10 provides details about the BCM system boot times and LED sequence using the Startup Profile to configure system parameters.

Table 10 Startup Profile times and LED sequence

Duration (minutes)	Cumulative time (minutes)	Power LED	Status LED	Comments
2	2	Solid green	Flashing green	
4	6	Solid red	off	
2	8	Solid green	Solid green	Initial boot sequence complete
30	38	Solid red	Solid green	Startup Profile functioning. Duration varies depending on selected parameters.
2	40	Solid green	Flashing green Off (error)	Startup Profile is successfully applied. If there is an error the remaining steps are not completed.
4	44	Solid red	off	Duration varies based on selected parameters.
2	46	Solid green	Solid green	Reboot complete and system is functional. Note: You can safely remove USB device.
<p>Note 1: If you use Element Manager to configure the parameters, the overall times are similar. Startup Profile enables you to configure multiple parameters at once, rather than individually using Element Manager.</p> <p>Note 2: To re-apply the Startup Profile, remove the applied keycode file by returning the system to factory defaults using the BIT tool.</p>				

Configuring the MBMs

You must configure the MBMs to function with your BCM system.

To configure the MBMs



1 minute/MBM

- 1 Open BCM Element Manager and connect to your BCM system.
- 2 From the **Configuration** tab, click the **Resources** folder to expand it.
- 3 Select **Telephony Resources** from the Resources folder (see [Figure 12](#)).

Figure 12 Telephony Resources page

Bus	Prog Type	Actual Type	Dip Sw	State	Devices	Low	Hi
0	N/A	IP Trunks	N/A	N/A	Lines		1
1	N/A	IP & App Sets	N/A	Enabled	Sets		N/A
2	Trunk Mod	None	N/A	Unequipped	Lines		N/A
2.0	Strn Mod	None	xxx111	N/A	Lines		211
3	ASM	None	N/A	Unequipped	Lines		N/A
3.0	BRI-ST4	None	x11110	N/A	Lines		301
3.1	Loop	None	x10110	N/A	Lines		189

- 4 In the **Modules** section, select the row of the MBM that you want to configure.
- 5 Double-click the **Prog Type** field to display the drop-down list.
- 6 Select the type of MBM that you installed in that location.
- 7 Click **Enable**.
- 8 Repeat steps 4 to 7 to enable each MBM in your system.

You can set other parameters for the MBMs depending on the type of MBM you installed.

Customizing other parameters

You can also customize the following parameters:

- Security policies (see the *BCM 4.0 Administration Guide*)
- Modem settings (see the *BCM 4.0 Networking Configuration Guide*)
- Software updates (see the *BCM 4.0 Administration Guide*)
- Voice mail (see the *CallPilot Manager Set Up and Operation Guide* for information on using the web-based interface to configure your voice mail system, or see the *CallPilot Telephone Administration Guide* for information on using Telset Administration to configure your voice mail system)
- Backup and restore (see the *BCM 4.0 Administration Guide*)

